

Cedar Hill Road @ Kenmore Road

Thursday, October 19, 2017



The data presented here is for information purposes only and should not be considered authoritative for construction, geotechnical, engineering, navigational, legal, or other site-specific uses. The information shared is owned by the Transportation Division of the Engineering Department at the District of Saanich. Accuracy is not guaranteed.

DISTRICT OF SAANICH 2017 TRAFFIC COUNTS

Major Route: Cedar Hill Road
Minor Route: Kenmore Road
Date: Thursday, October 19, 2017
Filename: Cedar Hill@Kenmore-Oct19-2017.xls

Station #: TIN000538
Intersection Type: 3-leg east approach
East/West Route: Kenmore Road
Weather: Rain and wet

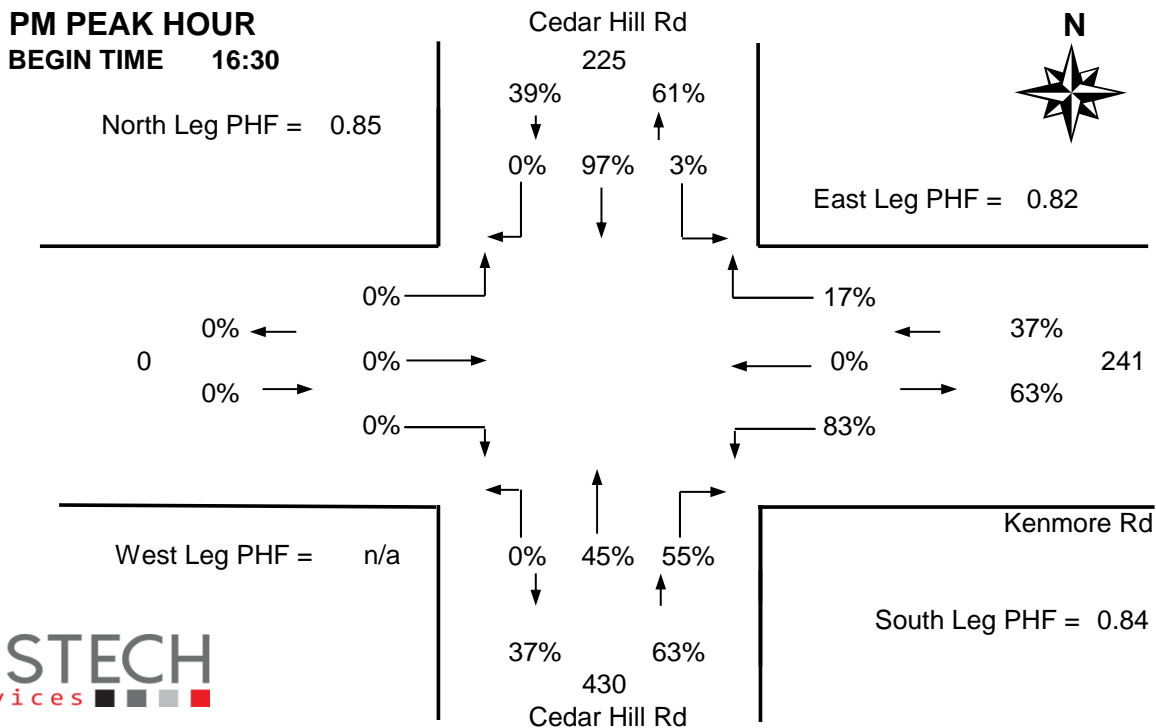
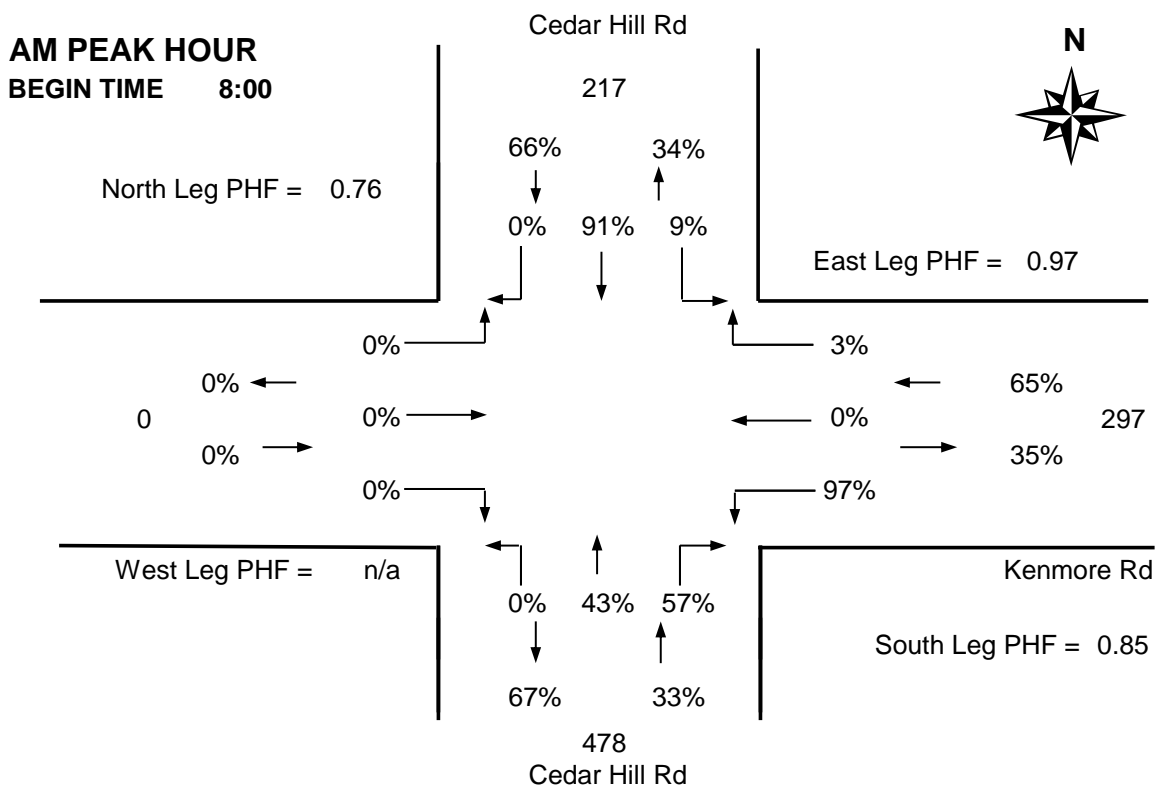

DISTRICT OF SAANICH 2017 TRAFFIC COUNTS

Major Route: Cedar Hill Road
Minor Route: Kenmore Road
Date: Thursday, October 19, 2017
Filename: Cedar Hill@Kenmore-Oct19-2017.xls

Station #: TIN000538
Intersection Type: 3-leg east approach
East/West Route: Kenmore Road
Weather: Rain and wet

Comments:

Vehicle Data

Time Period Starting	Cedar Hill Rd			Cedar Hill Rd			From West			Kenmore Rd			15 Min Total	Hourly Total	Pedestrians			
	From North			From South			Left	Thru	Right	From East					N	S	W	E
	Left	Thru	Right	Left	Thru	Right				Left	Thru	Right						
7:30	1	28			12	7				36		2	86	-	0	1		1
7:45	3	35			6	10				41		1	96	-	5	2		0
8:00	4	43			15	15				48		1	126 *	-	1	1		0
8:15	4	38			16	26				50		0	134 +	442	0	0		0
8:30	4	24			15	32				47		1	123 *	479	1	0		0
8:45	1	25			23	17				44		3	113 *	496	0	0		0
9:00	1	22			20	9				24		0	76	446	0	0		0
9:15	1	21			24	13				18		0	77	389	3	0		0
Total	19	236	0	0	131	129	0	0	0	308	0	8	831	-	10	4	0	1
Pk Hr	13	130	0	0	69	90	0	0	0	189	0	5	496 *	-	2	1	0	0
Pk Hr Factor	0.81	0.76	n/a	n/a	0.75	0.70	n/a	n/a	n/a	0.95	n/a	0.42	0.93	* = Peak hour + = Peak 15 minutes				
	0.76			0.85			n/a			0.97								
15:30	0	7			34	23				17		3	84	-	2	1		0
15:45	2	19			19	25				17		3	85	-	1	0		2
16:00	2	26			31	24				16		1	100	-	0	0		0
16:15	3	14			26	26				18		7	94	363	0	0		0
16:30	2	21			30	28				13		6	100 *	379	0	0		0
16:45	1	25			24	35				18		5	108 *	402	0	0		0
17:00	0	16			33	48				25		2	124 +	426	1	0		0
17:15	0	23			35	38				18		2	116 *	448	1	3		1
Total	10	151	0	0	232	247	0	0	0	142	0	29	811	-	5	4	0	3
Pk Hr	3	85	0	0	122	149	0	0	0	74	0	15	448 *	-	2	3	0	1
Pk Hr Factor	0.38	0.85	n/a	n/a	0.87	0.78	n/a	n/a	n/a	0.74	n/a	0.63	0.90					
	0.85			0.84			n/a			0.82								

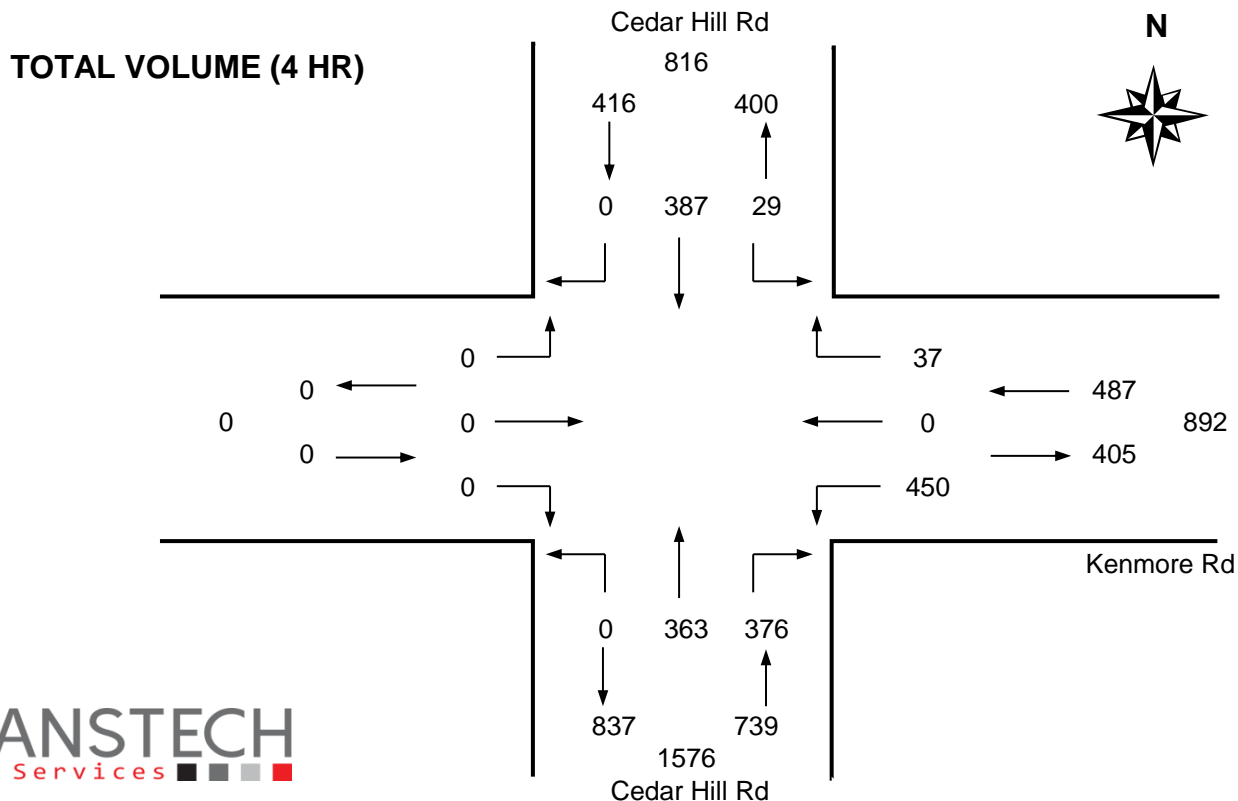

DISTRICT OF SAANICH 2017 TRAFFIC COUNTS

Major Route: Cedar Hill Road
Minor Route: Kenmore Road
Date: Thursday, October 19, 2017
Filename: Cedar Hill@Kenmore-Oct19-2017.xls

Station #: TIN000538
Intersection Type: 3-leg east approach
East/West Route: Kenmore Road
Weather: Rain and wet

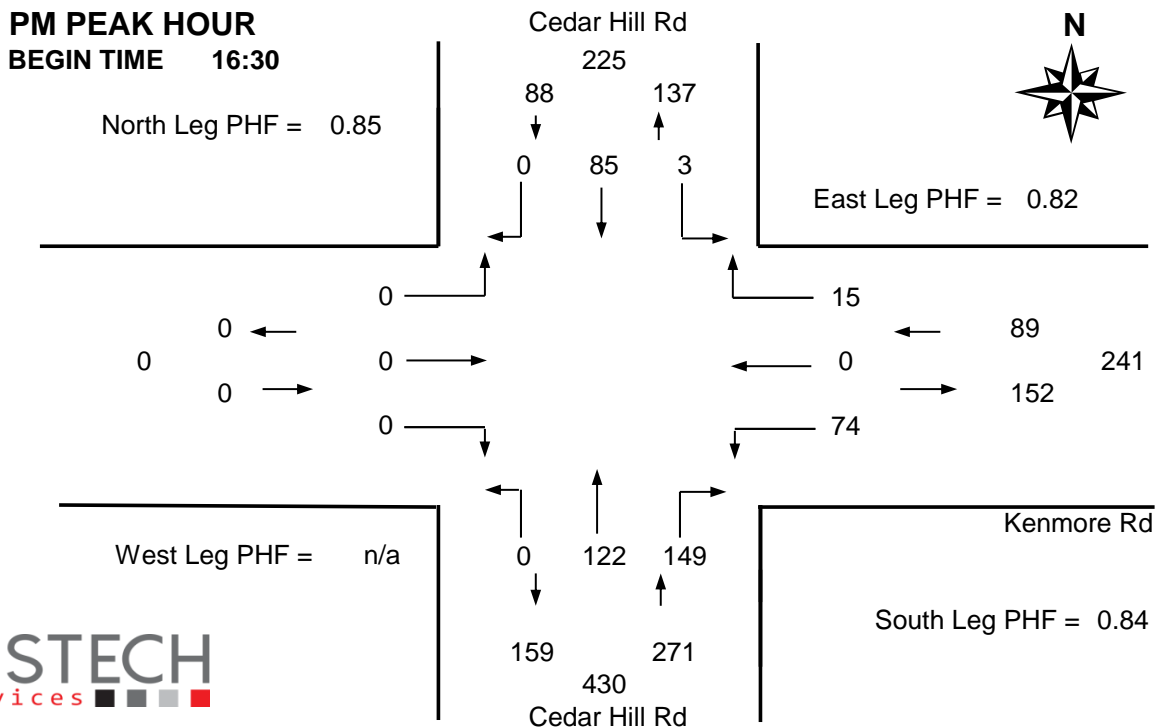
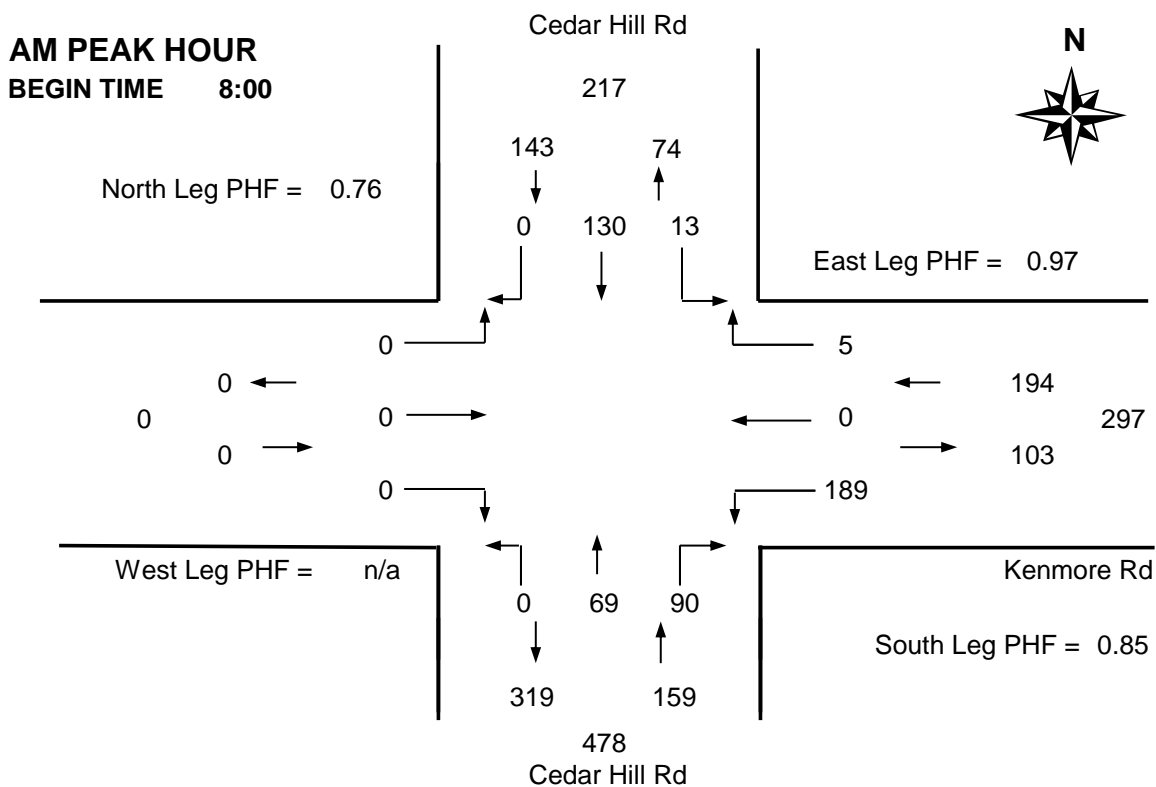

DISTRICT OF SAANICH 2017 TRAFFIC COUNTS

Major Route: Cedar Hill Road
Minor Route: Kenmore Road
Date: Thursday, October 19, 2017
Filename: Cedar Hill@Kenmore-Oct19-2017.xls

Station #: TIN000538
Intersection Type: 3-leg east approach
East/West Route: Kenmore Road
Weather: Rain and wet

Comments:

Bicycle Data

Time Period Starting	Cedar Hill Rd			Cedar Hill Rd			From West			Kenmore Rd			15 Min Total	Hourly Total
	From North			From South			From West			From East				
	Left	Thru	Right	Left	Thru	Right	Left	Thru	Right	Left	Thru	Right		
7:30	0	0			0	0				0		0	0 +	-
7:45	0	0			0	0				0		0	0 *	-
8:00	0	0			0	0				0		0	0 *	-
8:15	0	0			0	0				0		0	0 *	0
8:30	0	0			0	0				0		0	0	0
8:45	0	0			0	0				0		0	0	0
9:00	0	0			0	0				0		0	0	0
9:15	0	0			0	0				0		0	0	0
Total	0	0	0	0	0	0	0	0	0	0	0	0	0	-
Pk Hr	0	0	0	0	0	0	0	0	0	0	0	0	0 *	-
15x4	0	0	0	0	0	0	0	0	0	0	0	0	0 +	-

15:30	0	0			0	0				0		0	0	-
15:45	0	0			0	0				0		0	0	-
16:00	0	0			0	0				0		0	0	-
16:15	0	0			0	0				0		0	0 *	0
16:30	0	0			0	0				0		0	0 *	0
16:45	0	0			0	0				0		0	0 *	0
17:00	0	1			1	0				0		0	2 +	2
17:15	0	0			0	0				0		0	0	2
Total	0	1	0	0	1	0	0	0	0	0	0	0	2	-
Pk Hr	0	1	0	0	1	0	0	0	0	0	0	0	2 *	-
15x4	0	4	0	0	4	0	0	0	0	0	0	0	8 +	-

4 Hr	0	1	0	0	1	0	0	0	0	0	0	0	0	2	4
------	---	---	---	---	---	---	---	---	---	---	---	---	---	---	---

PEAK HOUR SUMMARY

